

# VSE48 ETL-12

## STAINLESS STEEL EXHAUST HOOD N.S.F. LISTED. CONFORMS TO NFPA96

Hood Constructed with continuous liquid-tight weld in conformance to IMC 2012 507.7.1.

Hood material: 18 Gauge 430 STAINLESS STEEL (#3 polish) where exposed.

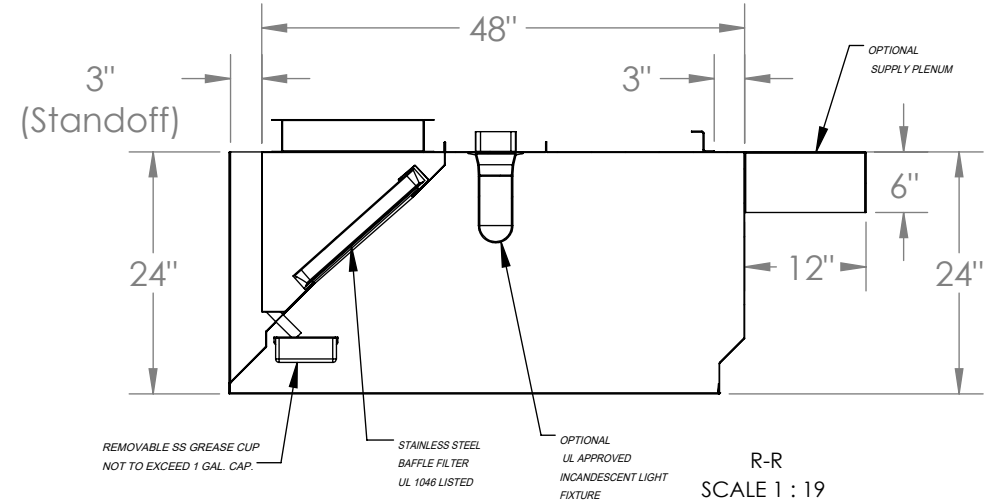
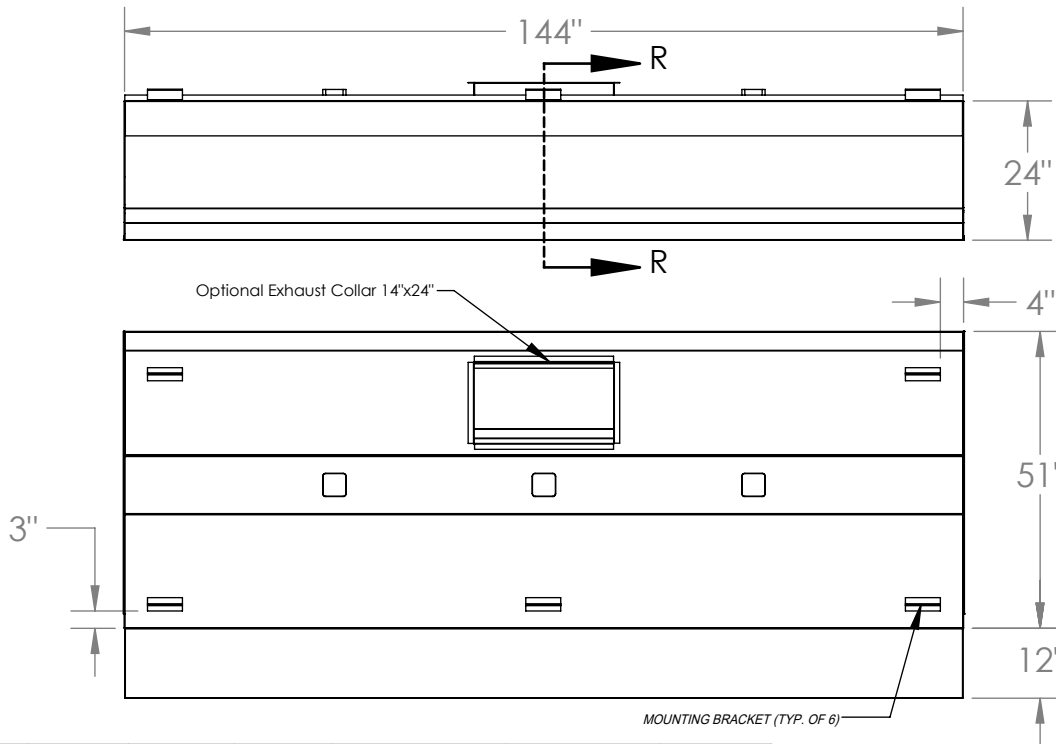

MODEL INFORMATION						
TYPE	DIMENSIONS			CFM SPECS		WEIGHT
1	LENGTH	WIDTH	HEIGHT	EXHAUST PLENUM	SUPPLY PLENUM <sup>1</sup>	382 lbs
	144"	51"	24"	3626 @ 0.5 ESP	2900 @ 0.12 ESP	

OBS.:  
Installing contractor have the responsibility to ensure hood clearance from limited-combustible and combustible materials is compliant with local code requirements.

<sup>1</sup> Sold Separately

STANDARD COMPONENTS INCLUDED							
MOUNTING BRACKET 12-GAUGE GALVANIZED	Incandescent Light Fixture	Standoff	Grease Drain	Grease Cup Stainless Steel NSF	Grease Filter Stainless Steel UL 1046		
QTY	UL Listed (Included Component)	3" back standoff included	QTY	QTY	QTY	Length	Height
6	QTY		2	2	0	16"	16"
	QTY		2		1	20"	16"
	3	5	25"		16"		

SUGGESTED COMPONENTS			
Exhaust Collar		Side Standoff	Shipping Crate
			Dimensions (in) and Weight (lb)
16-Gauge Cold Rolled Build		<input type="checkbox"/> NONE <input type="checkbox"/> 3" <input type="checkbox"/> _____	Length: 148"
			Width: 55"
			Height: 32"
QTY	Size		Weight: 502 lbs
1	14" x 24"		

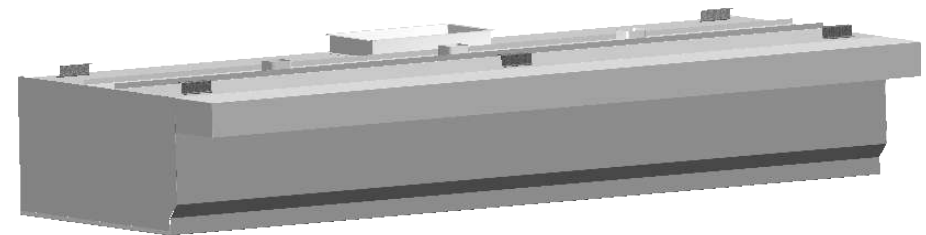

 PO BOX 47607 - ATLANTA, GA 30360 PHONE: 770.936.0770 - www.superiorhoods.com		PROJECT <b>VSE48 ETL-12</b>			
		TITLE <b>VSE48 ETL HOOD MODEL STANDARD SPEC SHEET</b>			
APPROVED	SIZE B	CODE	DWG NO	REV 01	
CHECKED					
DRAWN	PRODUCTION	2023	SCALE: 1:33	WEIGHT: 382 lbs	
				SHEET: 1/1	