

CSS30-9

STAINLESS STEEL EXHAUST HOOD N.S.F. LISTED. CONFORMS TO NFPA96

Hood Constructed with continuous liquid-tight weld in conformance to IMC 2012 507.7.1.

Hood material: 18 Gauge 430 STAINLESS STEEL (#3 polish) where exposed.

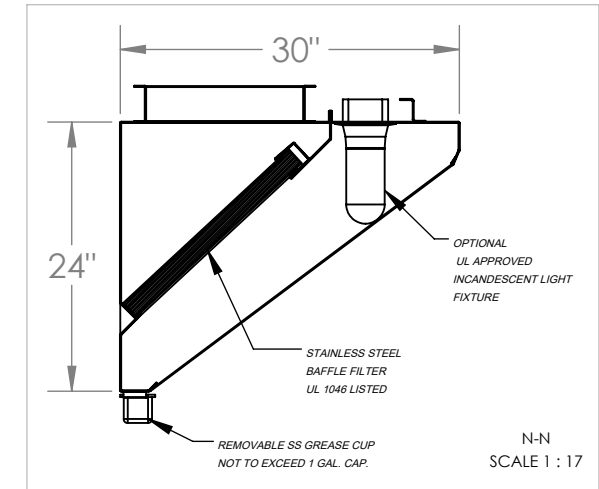
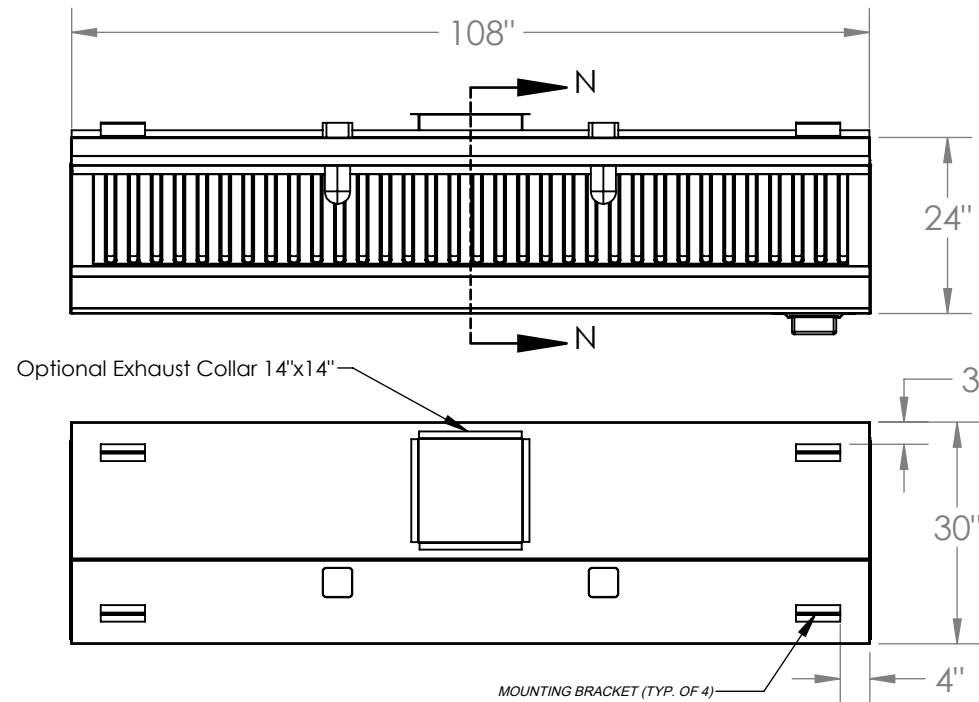



| MODEL INFORMATION | | | | | | |
|-------------------|------------|-------|--------|----------------|---------------|---------|
| TYPE | DIMENSIONS | | | CFM SPECS | | WEIGHT |
| | LENGTH | WIDTH | HEIGHT | EXHAUST PLENUM | SUPPLY PLENUM | |
| 1 | 108" | 30" | 24" | 2250 @ 0.5 ESP | N/A | 165 lbs |

OBS.: Installing contractor have the responsibility to ensure hood clearance from limited-combustible and combustible materials is compliant with local code requirements.

| STANDARD COMPONENTS | | | | | |
|---|-----------------|-----------------------------------|---|--------|--------|
| MOUNTING BRACKET 12-GAUGE GALVANIZED | Grease Drain | Grease Cup Stainless Steel NSF | Grease Filter Stainless Steel UL 1046 | | |
| QTY | QTY | QTY | QTY | Length | Height |
| 4 | 1 | 1 | 0 | 16" | 20" |
| | | | 4 | 20" | 20" |
| | | | 1 | 25" | 20" |

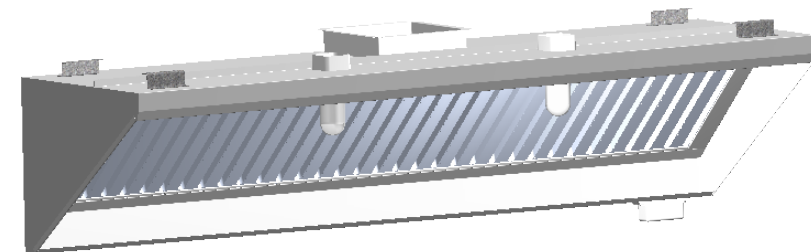
| SUGGESTED COMPONENTS | | | | | | |
|-------------------------------|-----------|---------------|------|--------------------------------------|------------------------------------|---------|
| Exhaust Collar | | Supply Collar | | Incandescent Light Fixture | Shipping Crate | |
| 16-Gauge Cold Rolled Build | | N/A | | UL Listed (Included Component) | Dimensions (in) and Weight (lb) | |
| QTY | Size | QTY | SIZE | QTY | Height: | Weight: |
| 1 | 14" x 14" | N/A | N/A | 2 | 32" | 255 lbs |



| | | | | | |
|--|-----------|--|------------|------|-------------|
|  PO BOX 47607 - ATLANTA, GA 30360 PHONE: 770.936.0770 - www.superiorhoods.com | | PROJECT CSS30-9 | | | |
| | | TITLE CSS30 HOOD MODEL STANDARD SPEC SHEET | | | |
| APPROVED | SIZE B | CODE | DWG NO | | REV 01 |
| CHECKED | DRAWN | | PRODUCTION | 2023 | SCALE: 1:26 |
| WEIGHT: 165 lbs | | SHEET: 1/1 | | | |