

CSS30-14

STAINLESS STEEL EXHAUST HOOD N.S.F. LISTED. CONFORMS TO NFPA96

Hood Constructed with continuous liquid-tight weld in conformance to IMC 2012 507.7.1.

Hood material: 18 Gauge 430 STAINLESS STEEL (#3 polish) where exposed.

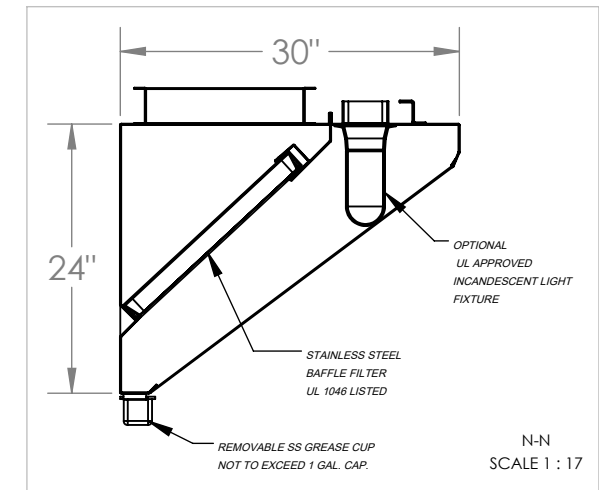
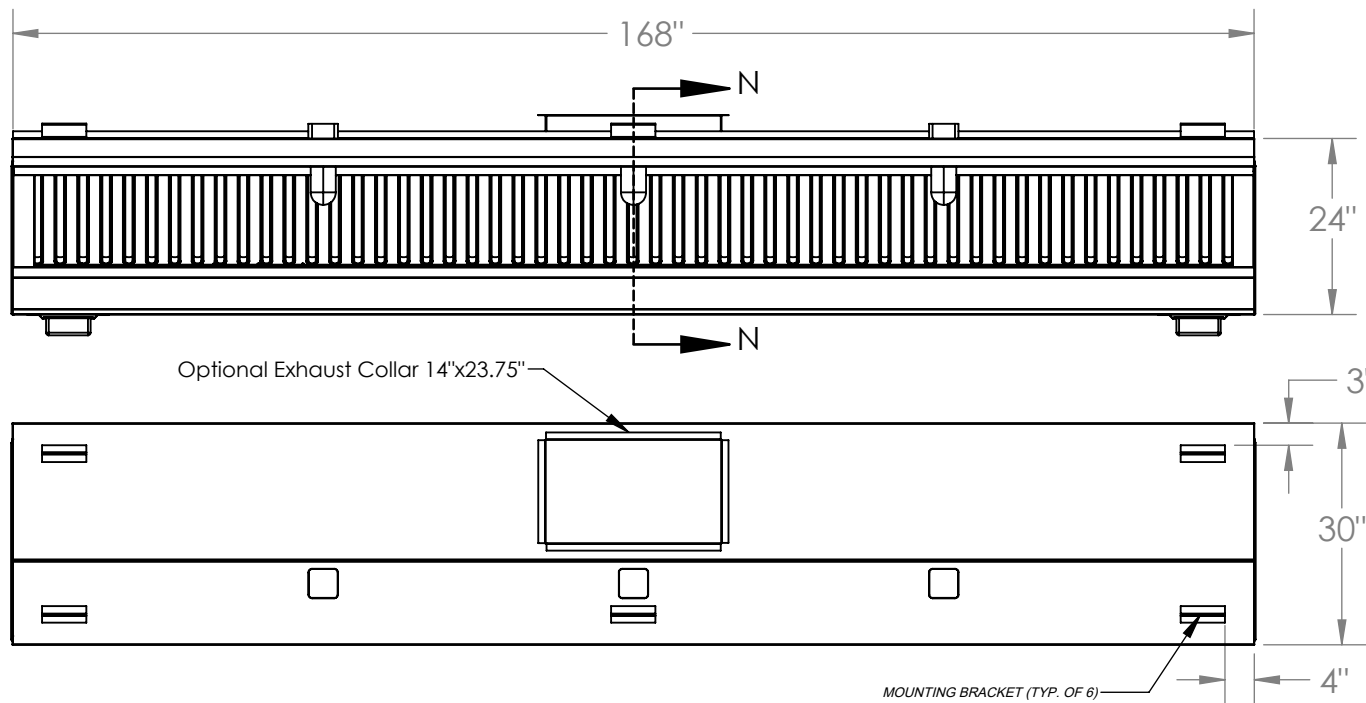



MODEL INFORMATION						
TYPE	DIMENSIONS			CFM SPECS		WEIGHT
	LENGTH	WIDTH	HEIGHT	EXHAUST PLENUM	SUPPLY PLENUM	
1	168"	30"	24"	3500 @ 0.5 ESP	N/A	249 lbs

OBS.: Installing contractor have the responsibility to ensure hood clearance from limited-combustible and combustible materials is compliant with local code requirements.

STANDARD COMPONENTS						
MOUNTING BRACKET 12-GAUGE GALVANIZED	Grease Drain	Grease Cup Stainless Steel NSF	Grease Filter Stainless Steel UL 1046			
QTY	QTY	QTY	QTY	Length	Height	
6	2	2	0	16"	20"	
			2	20"	20"	
			5	25"	20"	

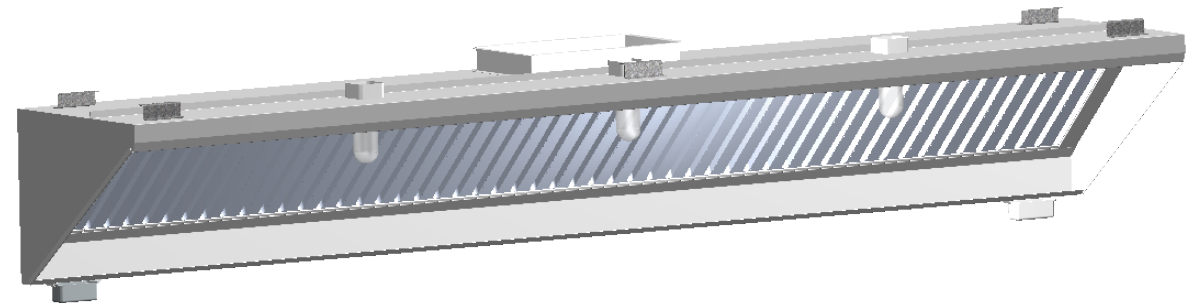
SUGGESTED COMPONENTS						
Exhaust Collar		Supply Collar		Incandescent Light Fixture	Shipping Crate	
16-Gauge Cold Rolled Build		N/A		UL Listed (Included Component)	Dimensions (in) and Weight (lb)	
QTY	Size	QTY	SIZE	QTY	Height:	Weight:
1	14" x 23.75"	N/A	N/A	3	32"	389 lbs



 PO BOX 47607 - ATLANTA, GA 30360 PHONE: 770.936.0770 - www.superiorhoods.com		PROJECT		CSS30-14		
		TITLE		CSS30 HOOD MODEL STANDARD SPEC SHEET		
APPROVED	SIZE B	CODE	DWG NO		REV	
CHECKED					01	
DRAWN	PRODUCTION	2023	SCALE: 1:26	WEIGHT: 249 lbs	SHEET: 1/1	